

STEP DATUM LINE:  
pls draw-in the ref. datum line that you use (i.e. firewall, leading edge, other?)

DRAW THIS SYMBOL ON ABOVE DIAGRAM AT LOCATION OF TYPICAL LOADED C.G.

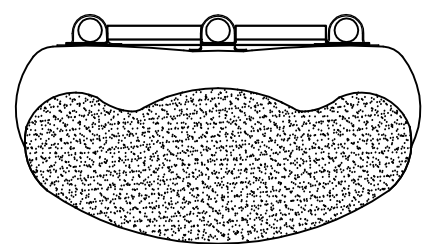

TO AIRCRAFT MANUFACTURER:

The information you provide will help us create drawings for the installation of our float system to your aircraft, you will then be able to provide these valuable diagrams to help your customers install floats on their aircraft. Please provide as much information as possible. Feel free to modify this template as necessary and return it to us by fax 705-526-8022 or email : myfloats@gmail.com If you have questions or need to discuss your particular set-up , please call Nick at 705-526-4537

FLOAT RIGGING DIM.		TUBE	PART DESCRIPTION	LENGTH
A	E	J	5" STREAM LINE SPREADER BAR	
B	F	K	3.5" STREAM LINE REAR STRUT	
C	S	M	3.5" STREAM LINE DIAGONAL STRUT	
D	T	N	3.5" STREAM LINE FRONT STRUT	

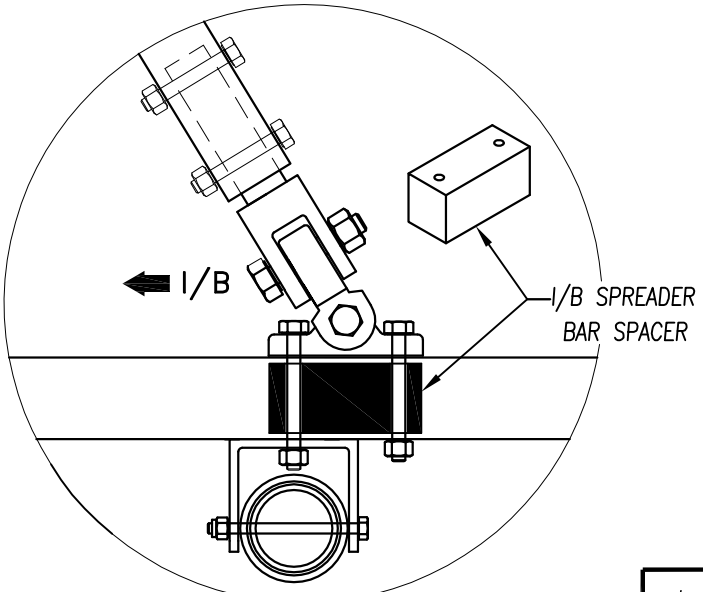
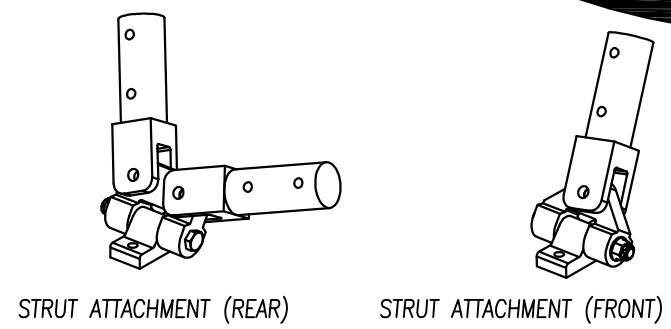

aircraft info. TYPE: MODEL:	FULL LOTUS FLOAT - RIGGING TEMPLATE SIZE:	
	AIRCRAFT FLOATS MANUFACTURING INC.	DATE: